

THE NEW SP SERIES

MAXIMUM CAPACITY – MINIMUM FOOTPRINT

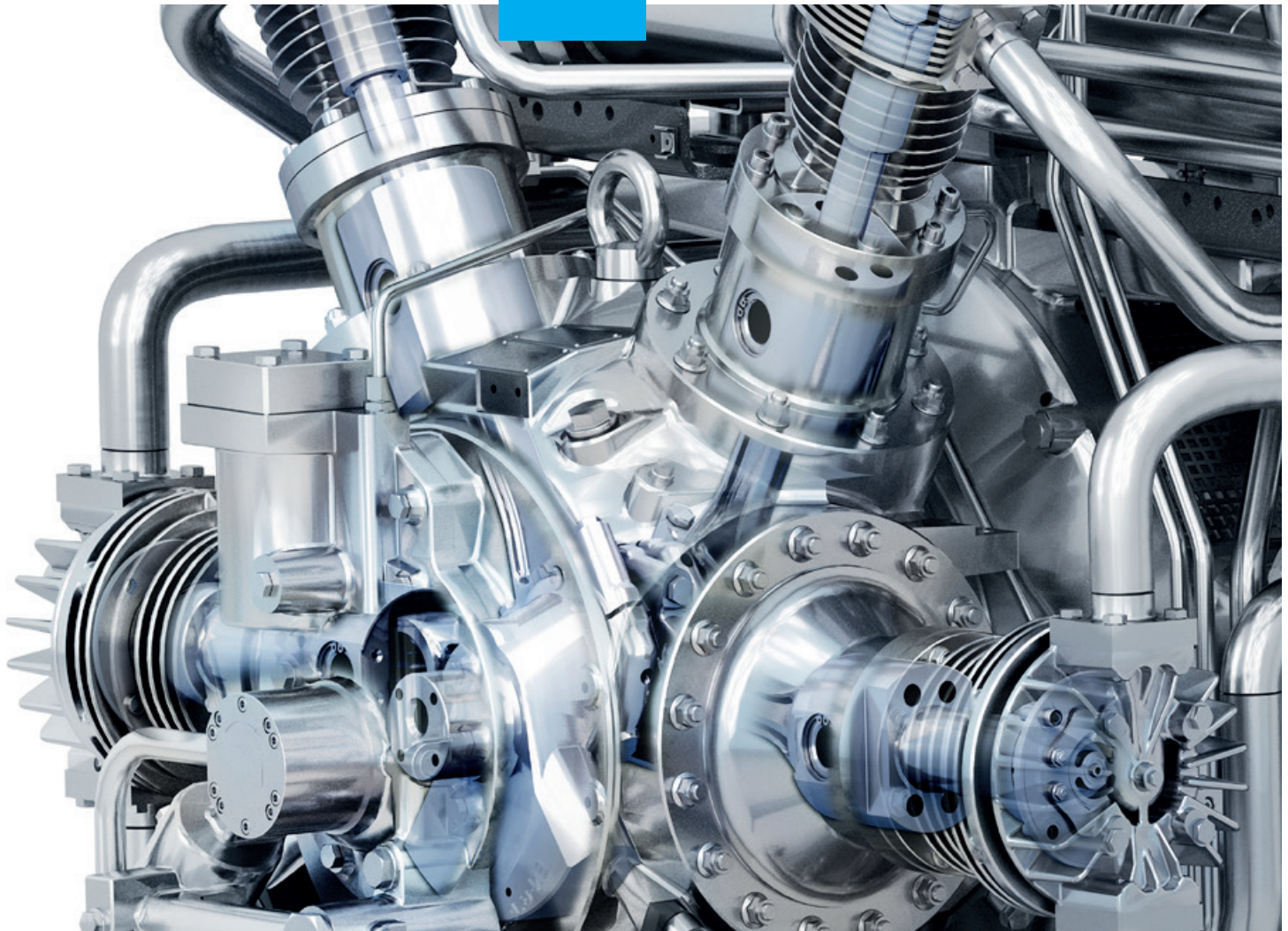

JOINT INNOVATION – THE CONCEPT BEHIND THE NEW SP SERIES

PISTON AND AIR END COMBINED IN A POWERFUL SYNTHESIS

When cost-effectiveness or limited space are critical factors, high-pressure compressors that deliver top performance from a compact footprint are the answer.

However, conventional high-pressure models are unlikely to fulfil these requirements.

BAUER's SP Series offers the ideal solution.

The series combines a BK 26 Series advanced high-pressure compressor block with a ROTORCOMP EVO[®]. The air end supplies air or gas at the intake pressure, which is then compressed to the defined final pressure by the high-pressure block. This design enables BAUER's SP systems to deliver extremely high F.A.D. rates despite their ultra-compact design.

All technology used in the SP system is developed within the BAUER GROUP. The perfect combination for a high-performance, compact compressor solution.

- › **110 - 520 bar**
- › **10400 - 15000 l/min**
- › **Water-cooled**
- › **Air/nitrogen**

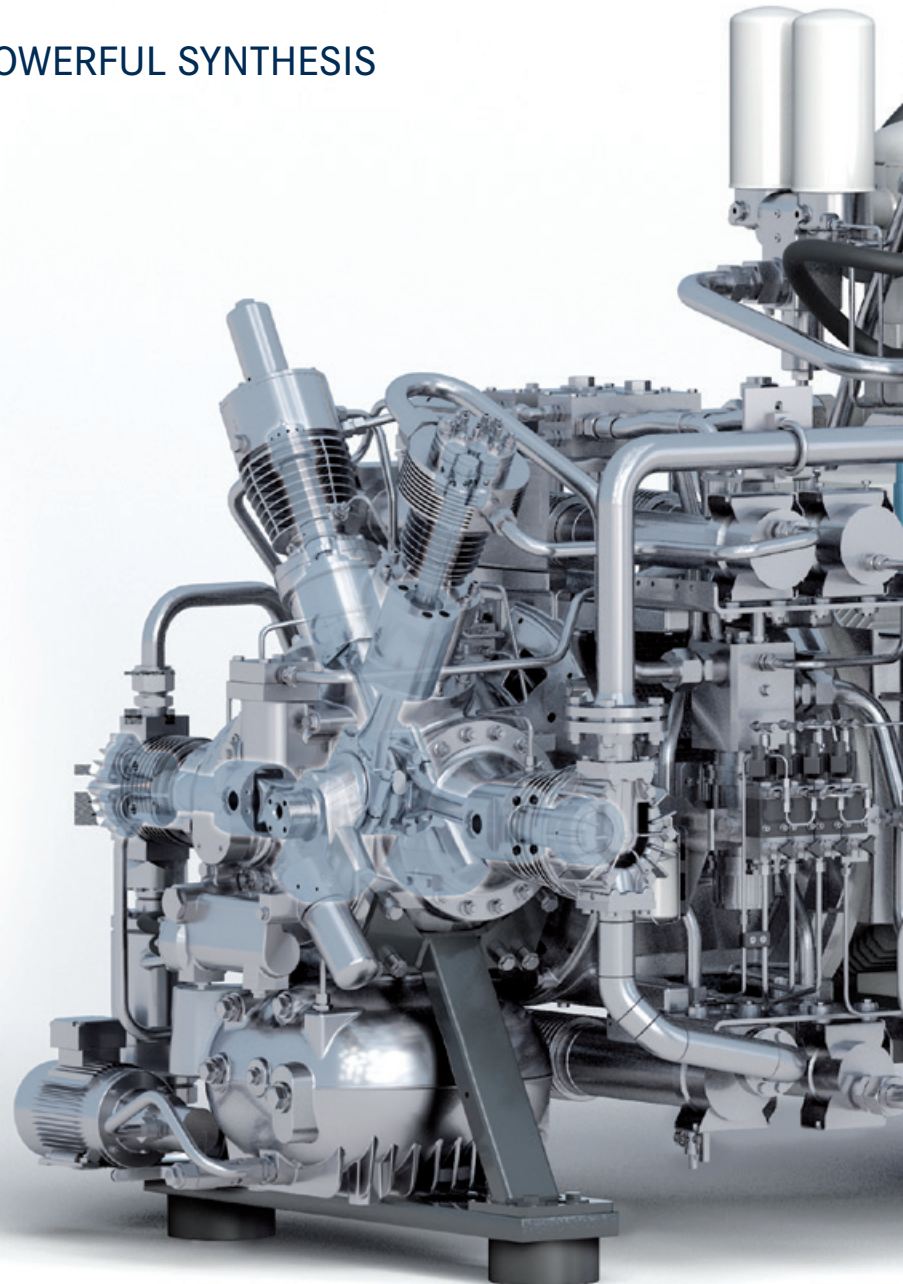

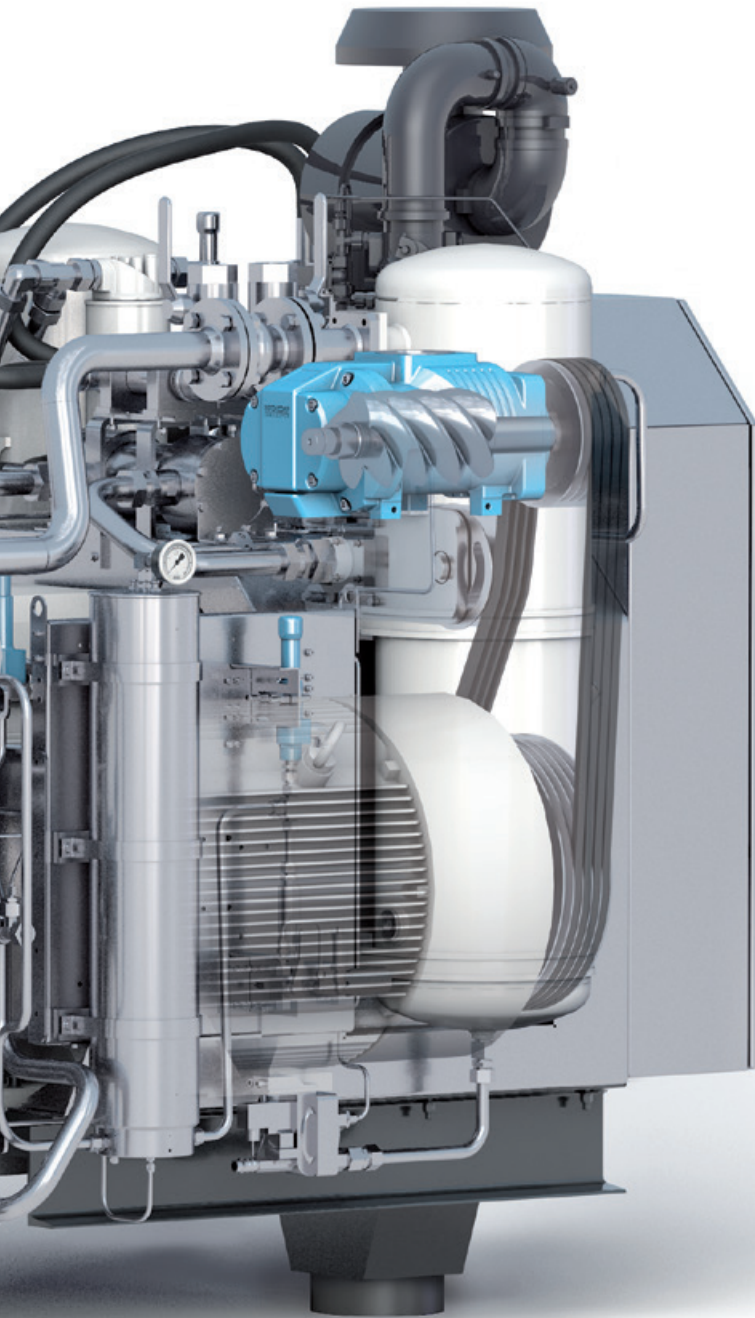

COMPACT AND POWERFUL

We've improved our outstanding BK 26 block still further, with even more compact dimensions and supremely quiet, low-vibration operation. The high-pressure lubrication unit is designed to allow the system to be used at extreme angles of up to 30° (roll/pitch), in situations such as on board ships.



FULL CONTROL

The compressor control unit B-CONTROL II drives the smooth interaction of the air end and piston block. In addition to control and monitoring of critical system functions, B-CONTROL II also offers convenient extra features including data logger, USB port, common interfaces such as Modbus, CAN Bus and Profibus, and an integrated control option for an interconnected system of up to four compressors.



TOP PERFORMER

The upstream ROTORCOMP EVO air end is precisely aligned to the high-pressure compressor block. It delivers precompressed air or gas in the volumes required – quietly, reliably and enduringly.

STATE OF THE ART TECHNOLOGY – THE PERFECT COMBINATION

THE NEW BK 26 – AN OUTSTANDING BLOCK JUST GOT EVEN BETTER

The new water-cooled BK 26 compressor block features extra-compact dimensions, ultra-quiet operation and extremely low thermal load. The high-pressure lubrication unit is designed to allow the system to be used at extreme angles of up to 30° (roll/pitch), in situations such as on board ships.

The redesigned BK 26 is now even sleeker and more compact. To achieve this, the heat exchanger was relocated to the central clutch cover.

With low oil consumption and low-maintenance operation, the BK 26 is also an ideal choice for continuous operation under challenging conditions, offering exceptional cost-effectiveness and low total costs of ownership (TCO).

In addition, the BK 26 block is now even quieter in operation. The design improvements have reduced free inertia forces, resulting in a further significant drop in vibrations. Vibrations and pulsations are now virtually undetectable.

The oil lubrication system has likewise undergone a complete redesign. With outstanding continuous operation characteristics, the new BK 26 is ideal for mission-critical applications requiring 24/7 operation.

Ease of access for servicing and improved cold start properties have now been perfected.

Interstage and final separators have also been optimised. Stainless steel ensures optimum corrosion resistance. Thanks to its new higher capacity, the compressor can now

handle compression of wet gases, and further design changes have significantly extended inspection intervals.

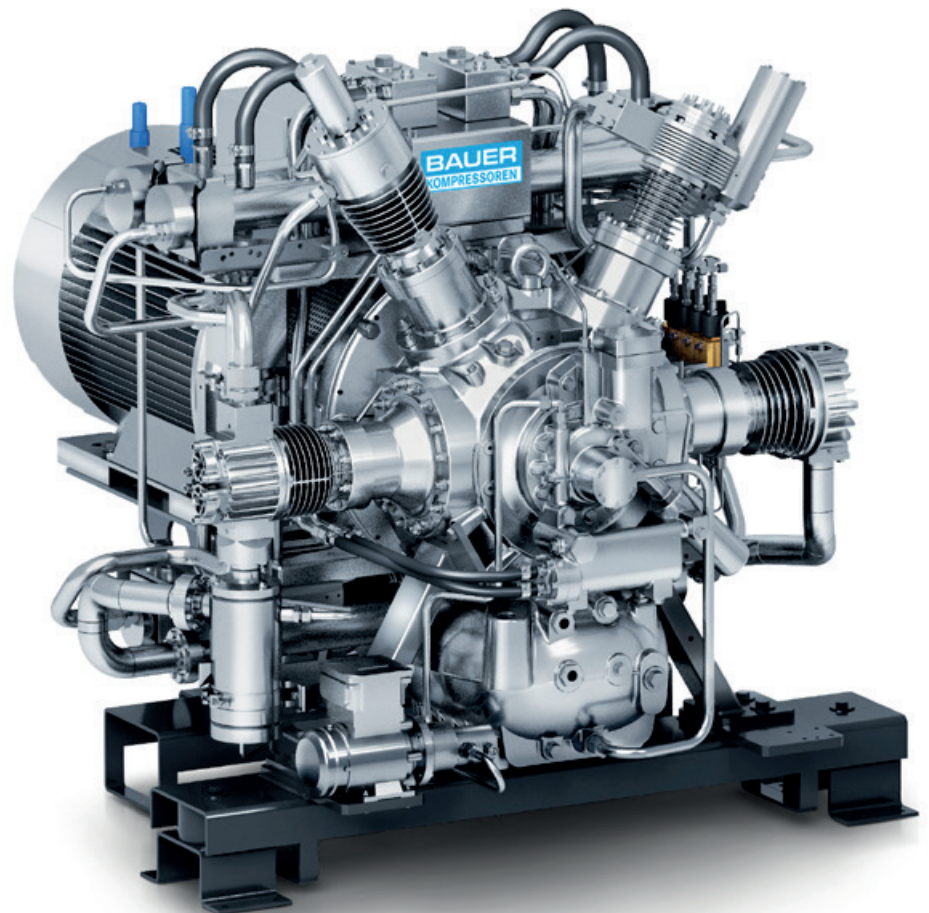

EVO AIR END – DELIVERING INTAKE PRESSURE AT TOP EFFICIENCY

The EVO air end delivers air at the intake pressure required by the high-compression compressor block. A ROTORCOMP product, it likewise has the “Made in Germany” quality seal.

The patented no-wear ROLLING PROFILE® screw profile combines outstanding efficiency with exceptionally smooth operation. As an added bonus, operating noise is also kept to an absolute minimum.

Thanks to the ROLLING PROFILE® and generously dimensioned bearings, the EVO is extremely resistant to wear, extending service life to the maximum and cutting total costs of ownership (TCO).

To maximise compression efficiency, the EVO® technology was advanced to include hydrodynamic optimisation of the oil injection system as well as optimised kinematics.

All lubricant channels are now internal, minimising pressure losses and streamlining the number of connections.

The downstream MULTIBLOCK fine separator efficiently extracts the oil from the air/gas before it passes into the high-pressure compressor block.

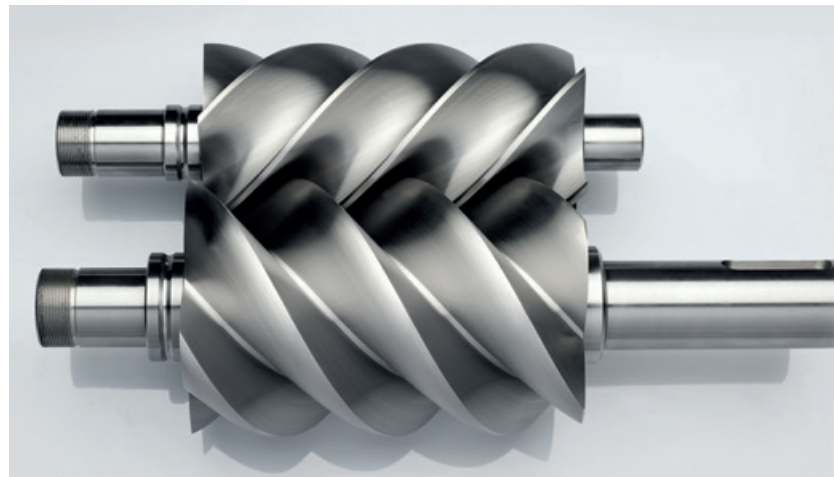
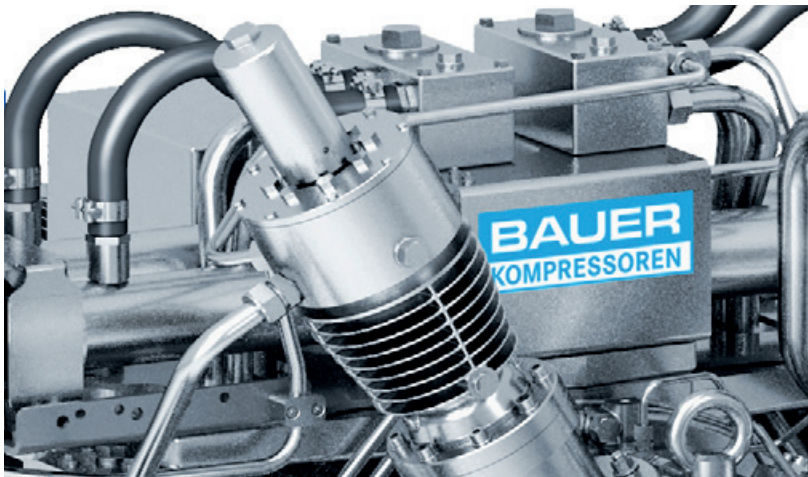

ACCESSORIES AND OPTIONS

BAUER ACCESSORIES SIGNIFICANTLY EXPAND YOUR SYSTEM'S OPTIONS

The applications of BAUER KOMPRESSOREN industrial compressor systems are as widespread as the requirements and needs of the various industries and applications they serve.

Our systems are universally designed on a modular basis; in conjunction with our extensive range of accessories, they can thus be tailored to virtually every requirement.

Medium or high pressure, air or nitrogen, specific air or gas properties or custom solutions for storage and distribution: whatever your needs, BAUER offers the ideal solution.

Our control systems significantly expand what your system can do – such as remote access for remote maintenance, or operation of a network of connected systems.

Special system housings combined with heating and cooling solutions enable BAUER systems to operate even in the most extreme ambient conditions.

By using stainless steel and adding special surface treatments and offshore coatings, we ensure our systems are fit for use in maritime applications in shipping or on offshore rigs.

Our trailer and container systems are ideal for mobile use or changing locations.

B-CONTROL II

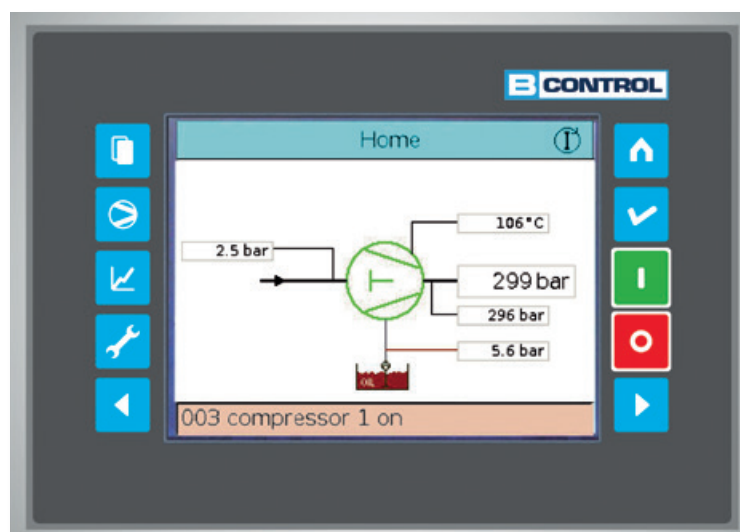

BAUER B-CONTROL II is a cutting-edge compressor control unit with 5.7" TFT colour touchscreen display. Easy to operate, it is the smart, secure way to manage all key functions of your compressor system.

In addition to controlling and monitoring critical system functions, B-CONTROL II also offers convenient extra features including data logger, USB port, common interfaces such as Modbus, CAN Bus and Profibus, and an integrated control option for an interconnected system of up to four compressors.

Further sensors and devices can be connected, e.g. interstage pressure and temperature monitors, data transmission via B-MESSENGER (SMS), remote control from an external control panel, VNC remote access via Ethernet etc.

COOLING SYSTEMS – EFFICIENT AND EFFECTIVE

In challenging locations or high ambient temperatures, BAUER cooling systems ensure that compressor systems can operate in optimum temperature ranges.

Closed-circuit or once-through cooling systems are available, depending on local requirements or connection options.

Plate heat exchangers can be used to ensure that the compressor's heat exchanger is not affected by contamination in fresh water cooling.

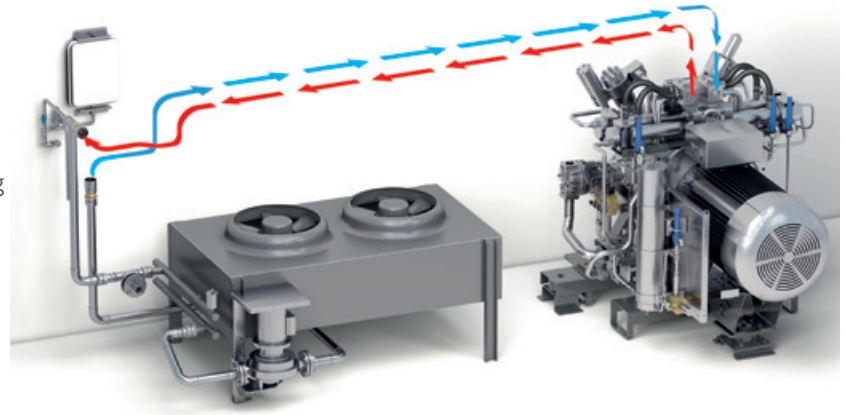

HOUSING AND CONTAINERS

BAUER supplies weatherproof custom housing for stationary installation of our systems or for mobile outdoor use.

Options range from standard shipping containers and special containers to customised individual housings that are designed and produced to specification. From fully air-conditioned systems for use in locations with high ambient temperatures to DNV-GL-certified containers for on- and offshore applications, the range of possibilities is virtually unlimited. Further options span individual design and alignment of a housing model to the customer's corporate design.



STORAGE SYSTEMS

BAUER supplies high-pressure storage systems with high-pressure storage cylinders that can be scaled up to any requirement. The storage systems comprise individual high-pressure cylinders, mounted in a shared frame. They are designed for indoor or outdoor use and are optionally available in separate weatherproof metal or concrete housings.



TECHNICAL DATA

AIR

Model	F.A.D. ¹			Max. operating pressure ²		No. of stages	Speed rpm	Motor-power kW	Power-consumption ¹ kW	Net weight approx.		
	l/min	m ³ /h	cfm	bar	psig					kg	lbs	
BK 26-SP SERIES												
GIB 26.7-SP-110	15000	900	530	110	1600	3	1485	315	260	4600	10200	
GIB 26.12-SP-365	10400	624	367	365	5300	5	1485	250	213	4400	9700	
GIB 26.12-SP-420	10400	624	367	420	6100	5	1485	250	220	4400	9700	
GIB 26.12-SP-520	10400	624	367	520	7540	5	1485	250	227	4400	9700	

¹ Volume flow rate according to ISO 1217; power consumption at max. final pressure under defined framework conditions.
Different ambient conditions will result in differing performance values. Directly coupled compressor units: values valid for 50 Hz.

² Maximum allowable working pressure = max. setting safety valve; final pressure (shut-down pressure) lower.

BAUER KOMPRESSOREN GmbH

Stäblistr. 8

81477 München

Tel. +49 (0) 89 78049-0

Fax +49 (0) 89 78049-167

info@bauer-kompressoren.de

bauer-kompressoren.de



SP Series EN

N42258

02.2021

Subject to technical change without notice